

26305 Mini Flash Trigger for Panasonic/Fujifilm

Instruction Manual

FOREWORD

Thank you for your purchase of a NAUTICAM product.

At NAUTICAM, we pride ourselves in the ability to recognize the requirements of professional as well as amateur underwater photographers and fulfill them through the innovative designs of our products. We strive to achieve a high level of user-friendliness by allowing stress-free installation and easy operation of all important functions of the camera.

Please read this manual carefully before using the product, this will maximize its performance as well as its lifetime.

WARRANTY

All NAUTICAM Products are warranted against any material and manufacturing defects for two years from the date of purchase for consumer use. This warranty only applies to products purchased from authorized NAUTICAM dealers and does not extend beyond the original retail purchaser.

To return your product for service, please contact your regional authorized service center(s). Please note that this warranty only applies when the product is purchased in the territory where the service center is located.

NAUTICAM does not hold responsibility for damage, of any nature, to any equipment used with and/or placed within our products.

NAUTICAM accepts no liability for any loss of captured images or the inability to capture images even if it is due to the malfunctioning of our products.

Unauthorized modifications and/or repairs of our products will automatically invalidate the warranty.

PRECAUTIONS

- Use only batteries approved for use in this product, do not mix old and new batteries.
- Check the battery terminals before installing into the product.
- Remove batteries for storage, do not store the product in an environment of high humidity.
- Do not leave the product in direct sunlight for prolonged periods.
- Keep out of reach of children, failure to do so could result in injury.
- Defective products should be shipped to our distributors for service, unauthorized disassembling and/or modifications could result in malfunction.

IDENTIFICATION OF PARTS



BATTERIES INSTALLATION

Make sure the On/Off switch is in the OFF position. Remove the battery compartment cover by sliding it outwards.



Install the batteries (Panasonic CR2450 x2pcs) with +ve terminal facing up as shown above. Close the battery compartment cover and then switch the trigger unit on. The indicator will turn green.

Indicator	Status of flash trigger
Green light	Start up.
Flashing Green light (1 flash/sec)	Ready to use, normal operation.
Flashing Red light (1 flash/sec)	Low battery warning, replace batteries.

CONNECT TO THE CAMERA



Align the flash trigger hotshoe connector to the camera hotshoe and slide in until it cannot go in any further. Test the flash trigger by pressing the shutter release button of the camera, the LEDs in the front should turn on instantaneously.

HOUSING PREPARATION FOR NA-XT1 / NA-XT2 / NA-XT3/XT4

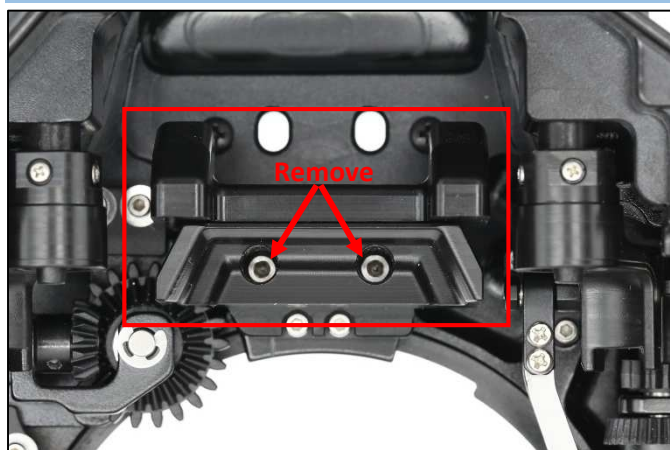

Remove the holder by removing the two screws as indicated above.



Remove the top part of the holder by removing the two screws.



Remove the top part of the holder by removing the two screws



Install the bottom part of the holder back into the housing



Install the bottom part of the holder back into the housing



Install the camera with flash trigger into the housing.



Install the camera with flash trigger into the housing.

HOUSING PREPARATION FOR NA-XH1

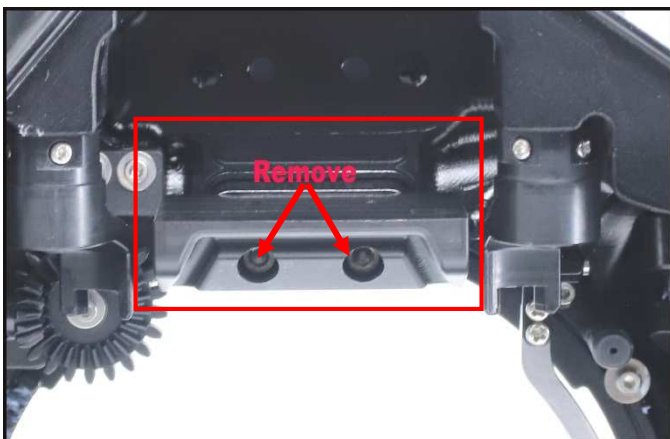

Remove the holder by removing the two screws as indicated above.

SPECIFICATIONS

Construction:	Body: PC+ABS
Dimensions:	Approx. 60 x 36 x 26.5mm
Weight:	Approx. 41g (w/ batteries installed)
Battery:	Panasonic CR2450 x2pcs
Operation:	This a manual flash trigger only and has no TTL function.
Flash Capacity:	Approx. 10000times
Compatible housings:	NA-GH4 / NA-XT1 / NA-XT2/XT3 /XH1 / XT4
Compatible strobes:	INON: Z240 type 4, D2000 type 4, S2000 Sea&Sea: YS-D2*, YS-250, YS-D1, YS-01 *with 26216 Universal Optical Fiber Cable

Remark: Nauticam supports only e-manuals. Please download corresponding product manuals on Nauticam.com website, or contact us for e-manuals.